

TO: Park & Recreation Commission Members
FROM: Bill Waller, City Administrator
Jon Steffes, Summer Recreation Director
DATE: May 4, 2020
RE: Meeting Notice
Tuesday, May 12, 2020
5:30 p.m., La Crescent City Hall
315 Main Street

AGENDA

1. Consideration of meeting minutes – January 21, 2020
2. Request from Lancer Youth Baseball/Softball to make improvements to the ball field at Veterans Park. Information regarding the request is included. Ryan Niedfeldt will be participating in the meeting to review the request and answer questions from the Commission.
3. Discussion regarding the 2020 Park & Recreation season, including the aquatic center and the balance of summer recreation programming. Sign-ups are presently set for May 16th and 18th. A summary of three scenarios for the 2020 summer recreation season is included, and will be reviewed at the meeting.
4. An update will be provided at the meeting regarding the following projects:
 - a. New playground equipment for Veterans Park – tentatively planned to be installed the last week in June.
 - b. Wagon Wheel Project – alternatives for the new bicycle/pedestrian bridge will be e-mailed out separately.
 - c. Replacement of park bleachers at Veterans Park. Spring 2020.
 - d. Helicopter at Veterans Park. Installed.
 - e. Bird City formal recognition event – May 21st at Vetsch Park. – Cancelled.
 - f. Arbor Day tree planting at Veteran’s Park – April 24th. Cancelled.
5. Additional Discussion Items.
6. Adjournment.

NOTICE

Please take notice that pursuant to Minn. Stat. Section 13D.021, members of the Park & Recreation Commisison may attend the meeting by telephone.

Please call me at 895-2595, or e-mail me at bwaller@cityoflacrescent-mn.gov, if you will not be able to attend, have questions, or need more information.

Thank you.

1

TO: Honorable Mayor and City Council Members
Park and Recreation Commission Members
FROM: Bill Waller, City Administrator
DATE: January 22, 2020
RE: Meeting Minutes
January 21, 2020

The La Crescent Park and Recreation Commission met at 5:30 p.m., on Tuesday, January 21, 2020, in the City Council Chambers at the La Crescent City Hall. The following members were present: Jon Steffes, Paul McLellan, Sarah Wetterlin, Diana Adamski, Randy Dobbs, and Eileen Krenz. Commission member Mike Limberg was not in attendance. Also in attendance were Jason Ludwigson and Bill Waller.

1. It was the consensus of the Commission to approve the minutes of the November 18, 2019 Park and Recreation Commission meeting as presented.
2. Jason Ludwigson was in attendance at the meeting to review the \$5,000 Statewide Health Improvement Partnership (SHIP) grant that the City has received for new wayfinding signs in the community. It was the consensus of the Commission to proceed with the project and finalize a plan for sign type and location, with the intent to purchase and install the signs in 2020.
3. The Commission was informed that the new log for the log rolling program and the new playground equipment for Veteran's Park have been delivered to the City.
4. The Commission was informed that the City has finalized the purchase of the property adjacent to Abnet Field and the La Crescent Community Arena as a potential site for outdoor skating/hockey and pickleball courts.
5. The Commission discussed the potential trail connection from Eagles Bluff Park to the Winona County Apple Blossom Overlook Park.
6. The Commission was updated on the status of the following projects: the stages of the Wagon Wheel project, the replacement of the bleachers at Veteran's Park, the helicopter at Veterans Park, the Bird City formal recognition event on May 21st, 2020, at Vetsch Park, the dog park, and a proposed new shelter at Veterans Park.
7. Commission member Diana Adamski provided an update regarding an evaluation that will be conducted this spring of potential sites for a disc golf course in the community.
8. It was agreed that the next Park and Recreation Commission meeting will be held on Tuesday, April 21, 2020, at 5:30 pm.
9. There being no further business to discuss, the meeting was adjourned at approximately 6:45 p.m.

#2

Bill Waller

From: Ryan Niedfeldt <ryan.niedfeldt@hps294.us>
Sent: Monday, May 4, 2020 9:02 AM
To: Bill Waller
Subject: Vets Field - Outline
Attachments: Vets Field

Hello Bill,

Here is a little outline of what the LYB and myself have envisioned for improvements to Vets Field:

Improvements for the remainder of 2020:

- a. Fix/stabilize the current and existing fence
- b. Create and build new dugouts with a roof over the top (a sketch drawing has been attached of our idea)
- c. Extend the infield dirt/lime in order for older age groups to play on that current field

Improvements for 2021 and beyond:

- a. Purchase or build a storage shed for equipment to be stored
- b. Outfield fence (permanent or temporary). Would Community Ed be needing the outfield for soccer anymore?
- c. More bleachers or grandstand for parents/families to sit
- d. Scoreboard
- e. Concession stand (it could be tied to the storage shed)
- f. Bathrooms
- g. Lights with the potential to play night games there at Vets Field

Can't build Rome in a day nor can we do this field but we have a wonderful resource/park that La Crescent could take pride in for future generations.

I am looking forward to the meeting and sharing our ideas in greater detail.

Thanks for your time,
Ryan Niedfeldt
952-937-2802

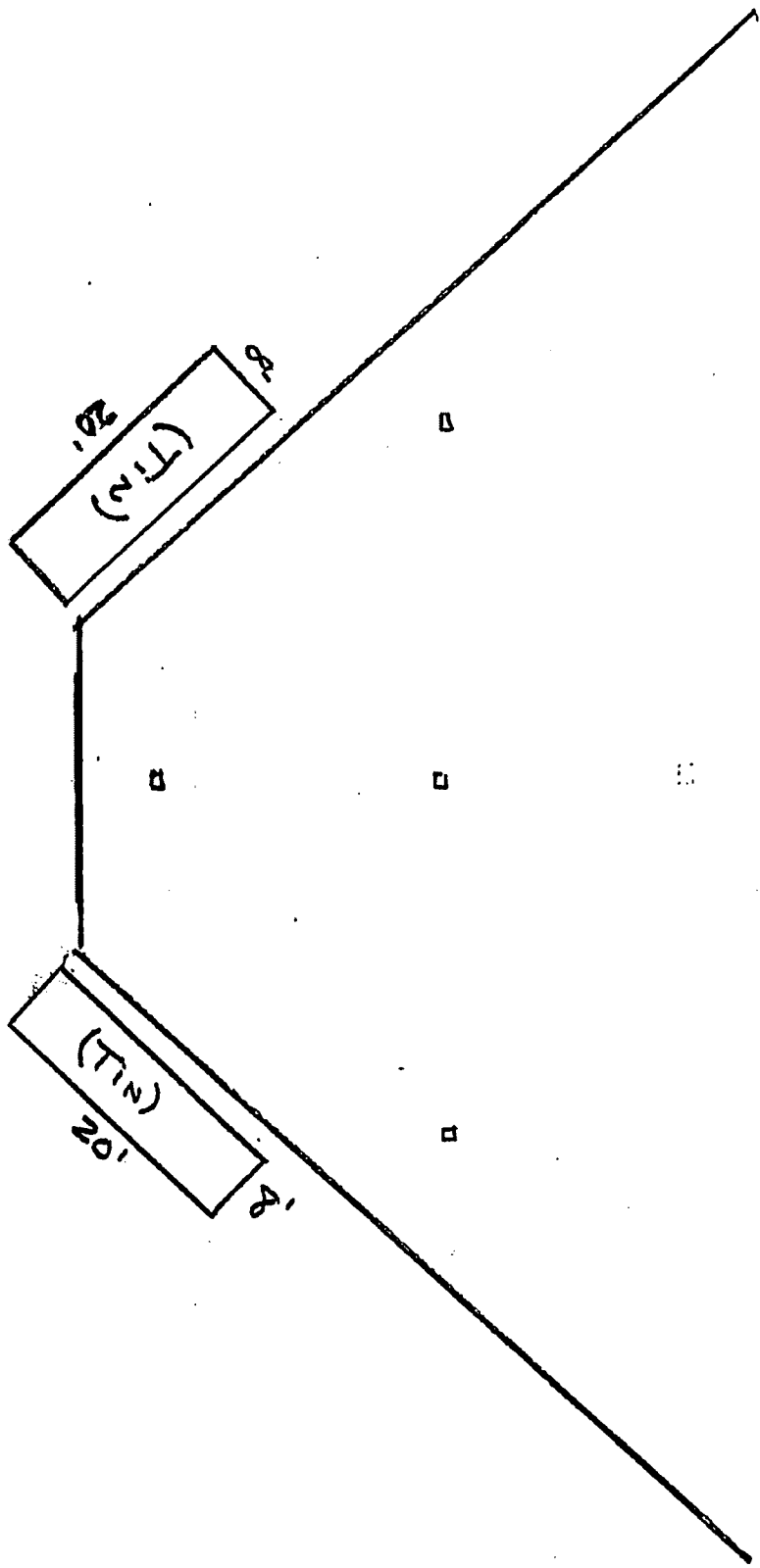

- Roof Cross tubes
- 4x4x1/8 tubes welded
- Tin Roof with Flashing
- Green Black Color
- Anchor with concrete Anchors

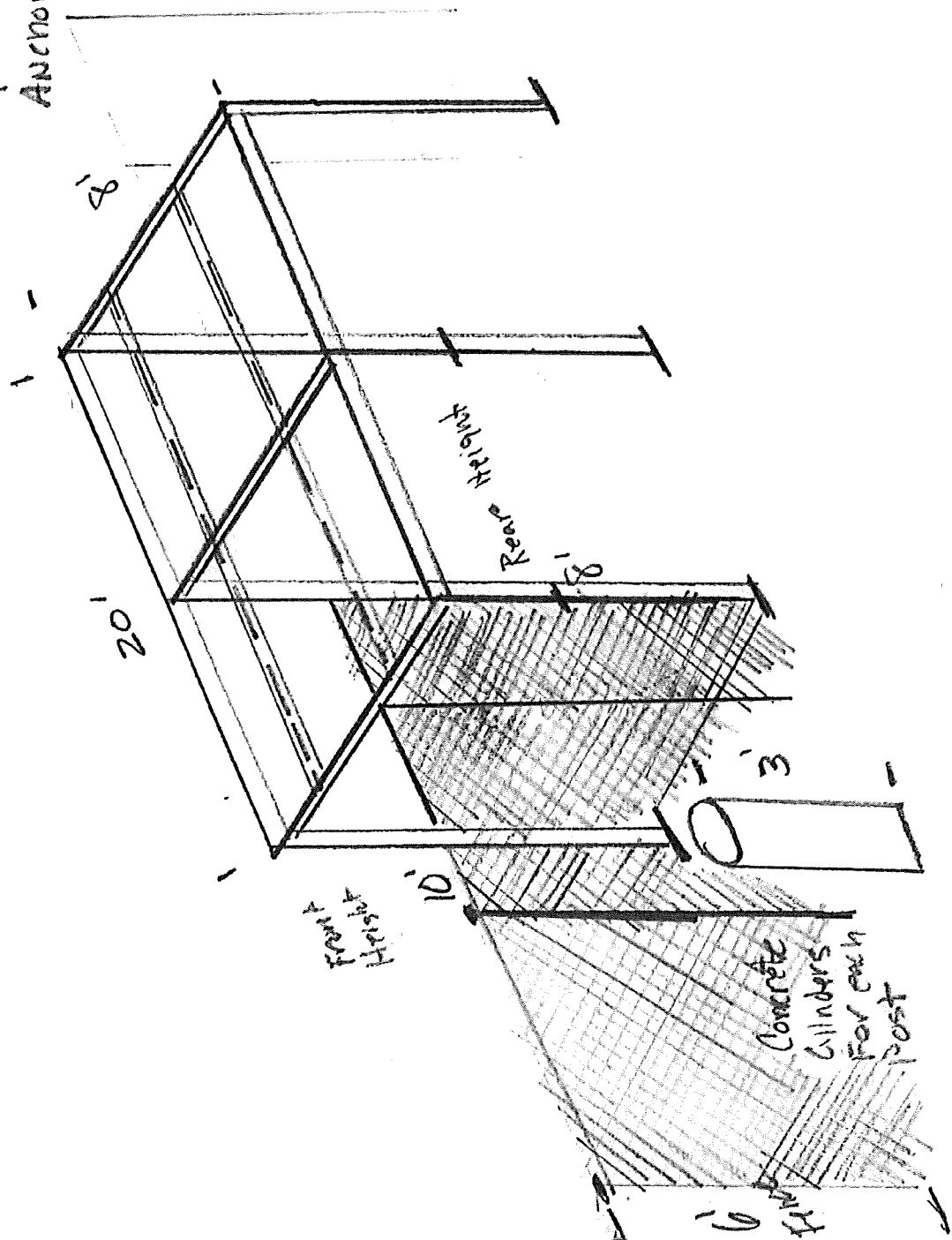

#3

2020 Summer Recreation Programming Possibilities

Plan A

Timeline stays the same

May 23 Pool opening, 5 sessions of swim lessons, August 22 Pool closing.

June 8th start for all other rec activities

Plan B

Timeline is moved back and programs shortened.

June 27 Pool opening, 4 sessions of swim lessons, August 27 Pool closing (if possible to go that late).

June 29th start for all other rec activities, shortened schedule, going until August 7th.

Plan C

Timeline is moved back and program length still shortened. Sports such as baseball go until August 7th, one week less in program length.

June 27 Pool opening, 4 sessions of swim lessons, close September 5th or 6th. Once the pool goes past the usual closing date (August 22) I would lose staff, which is why we would only do 4 sessions of swim lesson. We could also use some of those morning time slots to make up some school pool parties.

**Going past the August 22nd date is very dependent upon staffing. I usually lose all my guards to sports and college at that point. However, school doesn't start this fall until September 14th. Yet if students are busy with fall sports practices, it would be tough to go later.